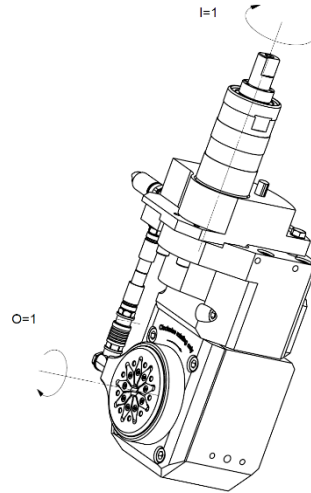

0800-SW016-RA0000-1S01

Machine: NexTurn

Type: SA20

SA32

Emplacement, N°: T07-T10

Travail sur: Broche principale

Type de travail:  n_{max} : 8'000 [rpm] $i (n_i / n_o)$: 1 / 1

Attachement: Changement rapide avec baïonnette

Refroidissement : Interne et externe en option

Infos:

- Inclinaison : $\pm 16^\circ$
- Têtes compatibles avec fixation rapide : Gloor, Schwanog
- \varnothing_{max} de passage 12 mm

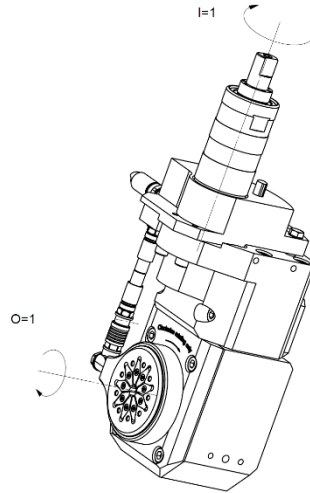
0800-SW016-RA0000-1S01

Machine: NexTurn

Type: SA20

SA32

Location, N°: T07-T10

Work on: Main spindle

Type of work: n_{max}: 8'000 [rpm]i (n_i / n_o): 1 / 1

Attachement: Quick change with bayonet

Coolant: Optional external and internal

Infos:

- Inclination : ±16°

- Compatible heads with quick attachment: Gloor, Schwanog

Ø_{max} passing 12mm

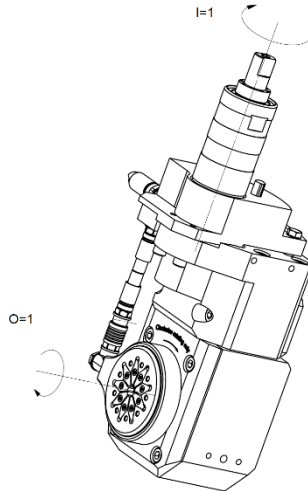
0800-SW016-RA0000-1S01

Maschine:	NexTurn
Typ:	SA20 SA32
Position, N°:	T07-T10
Arbeit über:	Hauptspindel
Arbeitstyp:	
n_{max} :	8'000 [rpm]
$i (n_i / n_o)$:	1 / 1
Befestigung:	Schnellwechsel mit Bajonett
Kühlmittel:	Optionale Innen und Aussen

Infos:

- Neigungswinkel : $\pm 16^\circ$
- Kompatible Köpfe mit Schnellverschlüssen : Gloor, Schwanog
- \varnothing_{max} durchgang 12mm

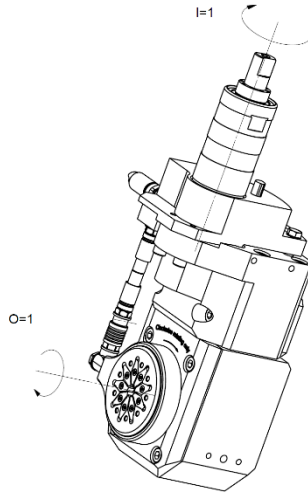
0800-SW016-RA0000-1S01

Macchina: NexTurn
Tipo: SA20
SA32
Posizione, N°: T07-T10
Lavoro al: Mandrino principale
Tipo di lavoro: 
 n_{max} : 8'000 [rpm]
 $i (n_i / n_o)$: 1 / 1
Ataccamento: Cambio rapido con baionetta
Refrigerante: Interno e esterno opzionale

Informazioni:

- Inclinazione : $\pm 16^\circ$
- Teste compatibili con fissaggi a sgancio rapido : Gloor, Schwanog
- \varnothing_{max} di passaggio 12mm