

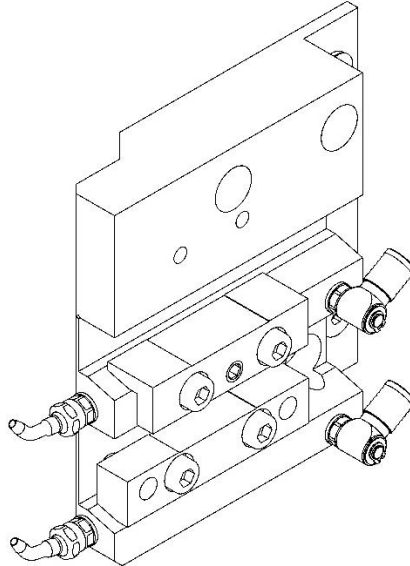





0400-TF160-R000K0-2S01

Machine: TSUGAMI
Type: B326 II
Emplacement, N°: Back gang tool post
Travail sur: Broche principale
Type de travail: 
n_{max}: -
i (n_i / n₀): -
Attachement: 1x 18.5 1x 29
Sans refroidissement
Infos:

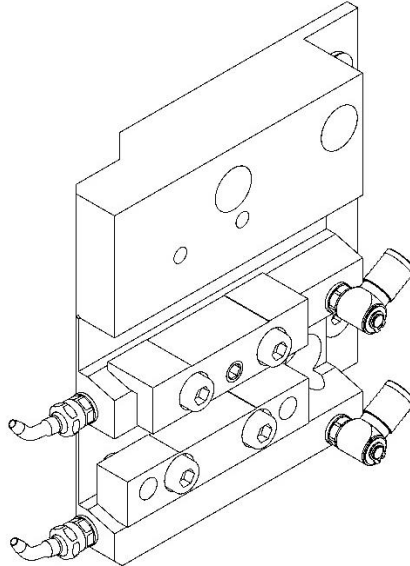
0400-TF160-R000K0-2S01

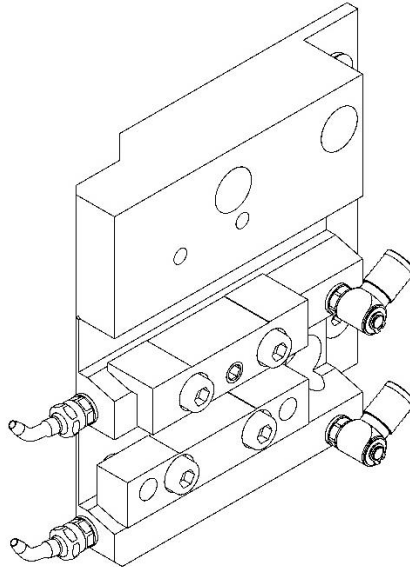
Machine: TSUGAMI
Type: B326 II
Location, N°: Back gang tool post
Work on: Main spindle
Type of work: 
n_{max}: -
i (n_i / n₀): -
Attachement: 1x 18.5 1x 29
Without coolant
Infos:

0400-TF160-R000K0-2S01

Maschine: TSUGAMI
Typ: B326 II
Position, N°: Back gang tool post
Arbeit über: Hauptspindel
Arbeitstyp: 
n_{max}: -
i (n_i / n_o): -
Befestigung: 1x 18.5 1x 29
Ohne Kühlmittel
Infos:

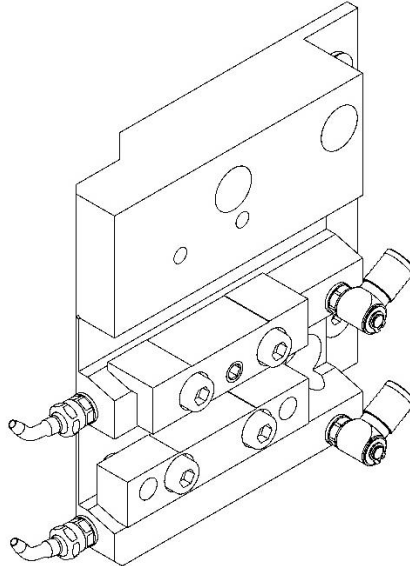
0400-TF160-R000K0-2S01

Macchina: TSUGAMI
Tipo: B326 II
Posizione, N°: Back gang tool post
Lavoro al: Mandrino principale
Tipo di lavoro: 
n_{max}: -
i (n_i / n_o): -
Atacco: 1x 18.5 1x 29
Senza refrigerante
Informazioni: